



TEK6 Datasheet

TEKdrive™ Servo Drives

General Description

The TEKdrive range of fast, smooth and accurate servo drives are specifically designed for use with Brushed or Brushless DC motors in small CNC machine applications. Utilisation of Step and Direction input signals enables the TEKdrive to replace direct stepper motors and deliver greater accuracy and increased speed. Easy to mount, compact and versatile, the TEKdrive range deliver greater power and accuracy for your application.

The TEK6 was designed specifically for lighter duty applications where high acceleration and high accuracy are required. With high speed processors and drivers capable of very high currents it can give fast and accurate control of both Brushed and Brushless DC motors. They are ideal for use in machines such as Plotters, Printers and Engravers, but will work equally as well in slower machines such as routers, where the fast acting PID can maintain a high degree of accuracy.

Features

- Power Output over 200W
- Dual high speed processors
- Full Serial PID adjustment during operation
- Fuzzy PID (F-PID) enhanced control.
- Delivers up to 8A continuous current
- Peak current over 30A
- Operates at supply voltages from 12-24VDC
- Speeds in excess of 1MHZ
- Tuning and Fault indicator LEDs
- Over Voltage/Temp/Current protection
- Minimal Heat Generation
- Analogue output of Following Error for tuning
- Encoder Fault detection

Applications

- High Speed, High Precision motion control.
- CNC Printers, Plotters and Engravers
- Small CNC Routers

Functional Diagram

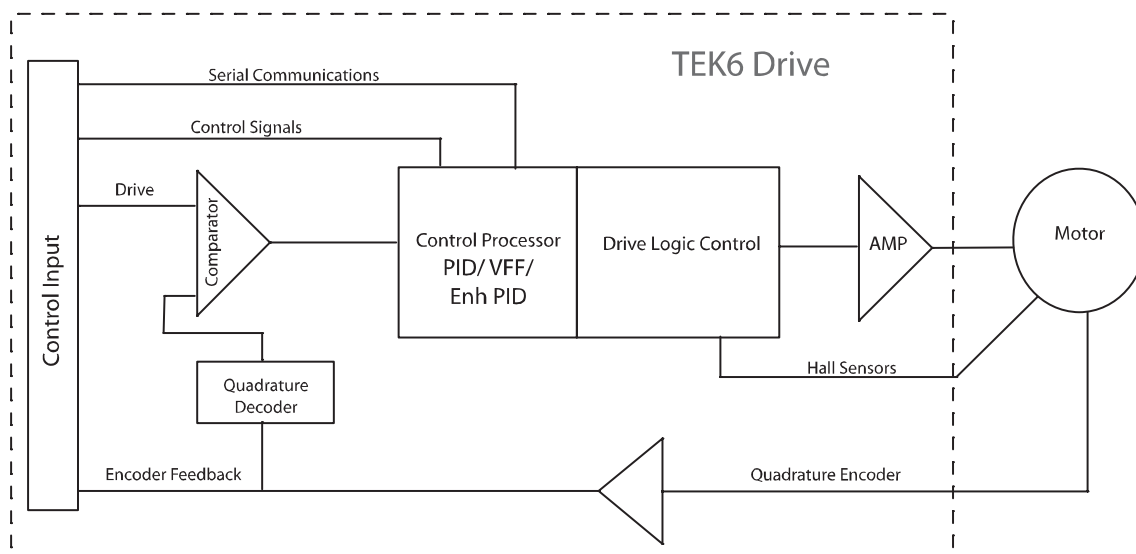

Figure 1 Functional block diagram of TEK6

Technical Specifications & Characteristics

Parameter	TEK6
Drive Specification	
Drive Voltage (Maximum)	28V,
Drive Voltage (Minimum)	12V,
Drive Voltage Ripple	<2% See Note 1
Drive Current (Peak) [Software Limited]	30A,
Drive Current (Continuous)	8A,
Drive Current Trip Value	30A,
Drive Current Trip Time	500mSec,
Servo Motor Resistance (Minimum)	1 ohm
Servo Motor Inductance (Minimum)	1mH
PWM Switch Frequency	25Khz
Logic Specification	
5V Logic Supply	5V @ 85mA
24V Driver Supply	24V @ 8A
Logic Level	3.3V – 5V TTL
Encoder Quadrature TTL Channels	2
Encoder Current (Maximum)	200mA
Encoder Pulse Frequency (Maximum)	1Mhz
Encoder following error trip	+/- 10 to +/- 2000 selectable
Encoder Voltage	5V +/- 10% 0.25A Maximum current draw
Physical Specification	
Dimensions	67mm (W) 26mm(H) 90mm(L) 2.63in (W) 1.02(H) 3.54 in(L)
Weight	42gms or 1.475oz
Mounting Hole Diameter	3.2mm
Motor / Power Terminals	Plug Header 15A
Hall Sensor	6 way Header 0.1"
Logic Connector	IDC10
Encoder Connector	RJ45
Operating Temperature Range	0 ~ 55 DegC RH 90% non condensing
Storage Temperature Range	-30 ~ 85 DegC RH 90% non condensing
Vibration/Shock Resistance	0.5/2G
Thermal Resistance	0.165R @ 80degC
Thermal Heat Dissipation (Maximum)	90W

Table 1 TEKdrive™ 6 technical specifications

NOTE:

1. The addition of a capacitor near the power input terminal may be required to reduce supply ripple voltage. This is particularly important when using high input voltages.

Connection Diagrams

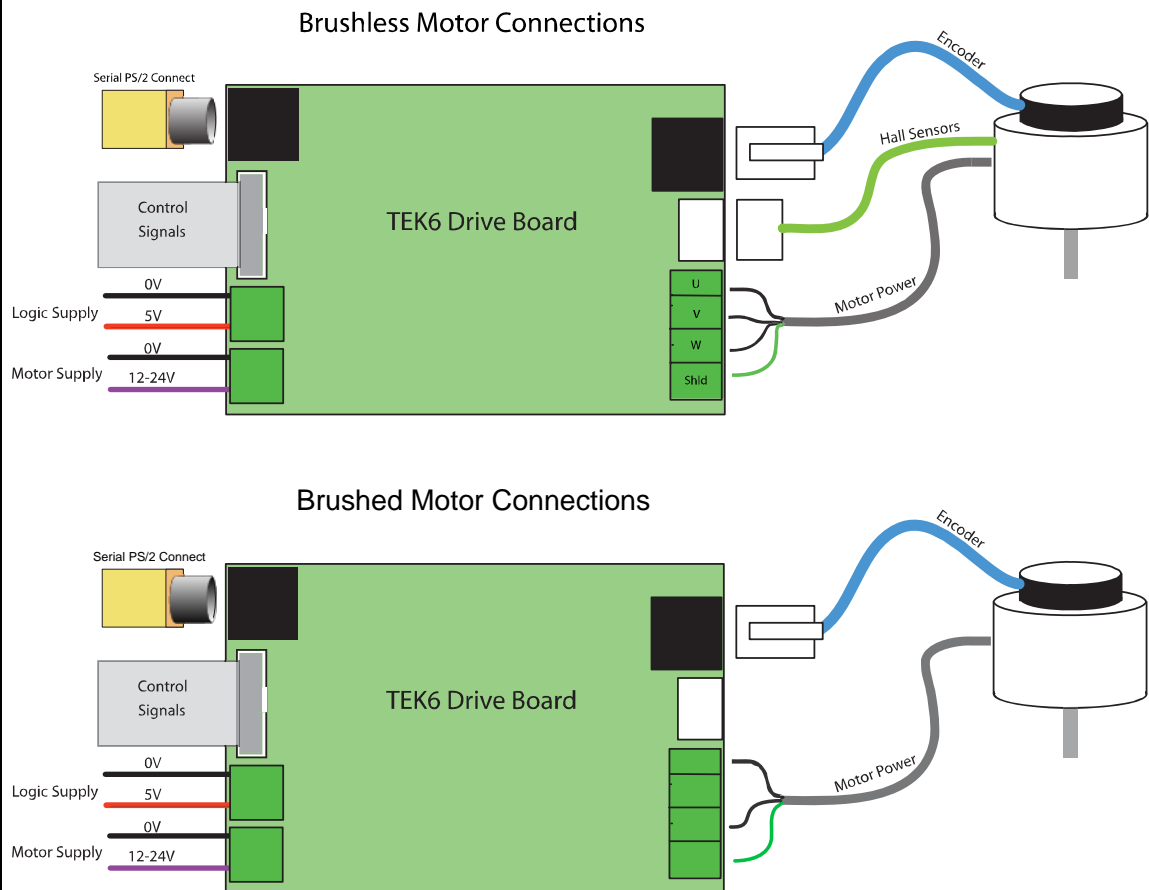

Figure 2 Diagram detailing all available connections

Figure 2, above, describes the connections for both Brushed DC and Brushless DC motors. The drive connections are all located along each end of the controller to provide easy access when mounted. The Motor Power supply and the Logic Power supply both share the same common ground, however to prevent any noise issues it is recommended that both be connected back to their source rather than join them together at the terminal.

For Brushless Motors it is important to get the Hall sensors and Motor Phases in the correct order, please check your motor datasheet to determine the correct connections for each motor phase and its equivalent Hall sensor connection.

I/O Descriptions

Logic Connector - IDC10			
Pin	Label	Description	
1	RX	Input – Serial (5V logic) RX connection for the tuning software.	
2	TX	Output - Serial (5V logic) TX connection for the tuning software.	
3	STEP	Input – The rising edge of the step input commands a single encoder step rotation in the direction selected by DIR.	
4	DIR	Input – A logic high selects a clockwise step and logic low a counter clockwise step.	
5	ChA	Output – Re-transmission of the encoder Channel A signal to the controller.	
6	ENABLE	Input – Logic high enables the driver to control the servo motor. Logic low stops all output to the servo motor.	
7	ChB	Output – Re-transmission of the encoder Channel B signal to the controller.	
8	RUN	Output – Logic high output indicating the drive is running correctly. If the drive is ENABLE and an error occurs the RUN output will indicate logic low.	
9/10	GND	Logic ground connection.	
Encoder Connector - RJ45 Connector			
Pin	Label	Description	
1	GND	Signal ground to encoder	
2	+5V	5V supply to encoder	
3/4	N/C		
5	CHA-	-Input of encoder channel A (Leave unconnected with single ended encoders)	
6	CHA	+ Input of encoder channel A	
7	CHB-	- Input of encoder channel B (Leave unconnected with single ended encoders)	
8	CHB	+ Input of encoder channel B	
	NOTE	Max voltage for any of the signal pins (3-8) is 15VDC (with external supply)	
5V Logic Supply - Header Terminal			
Pin	Label	Description	
1	-	0V logic supply Gnd	
2	+	5V logic supply positive.	
12-24V Motor Supply - Header Terminal			
Pin	Label	Description	
1	-	0V Motor Power Supply	
2	+	12-24V Motor Power Supply	
Hall Sensor - Header Terminal			
Pin	Label	Description	
1	+	5V logic supply positive.	
2		Hall Sensor – Phase U	
3		Hall Sensor – Phase V	
4		Hall Sensor – Phase W	
5	-	0V logic supply Gnd	
6		Cable Shield Gnd	
12-24V Motor – Header Terminal			
Pin	Label	Brushless DC	Brushed DC
1	U	Phase U	Motor +
2	V	Phase V	Motor -
3	W	Phase W	N/C
4	Gnd	Motor Cable Shield Earthing point	
PS/2 Serial Terminal			
Pin	Label	Description	
1/5		N/C	
2		RX (5V Serial protocol connection)	
3		Gnd	
4		5VDC	
6		TX (5V Serial protocol connection)	

Table 2 Input Output Descriptions for TEK6

TEK6 Dimensions

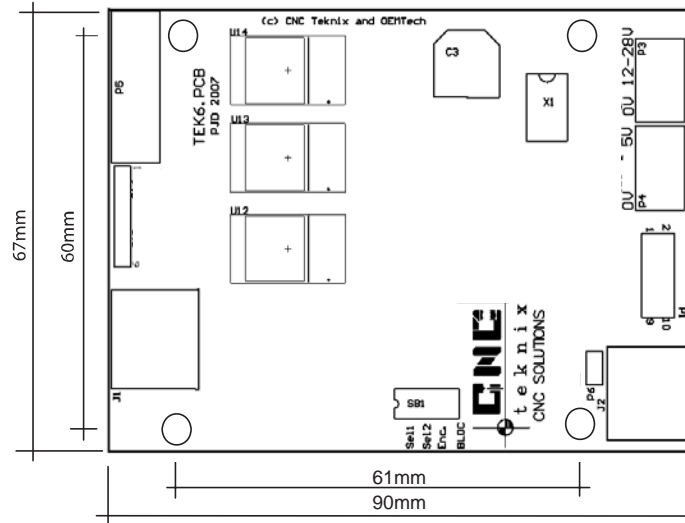

The mounting holes are 3.2mm diameter, suitable for mounting with 3mm screws.

A clearance of at least 6mm is required between the bottom surface of the PCB and any conductive mounting surface.

A clearance of at least 30mm is required above the board to accommodate the heatsink and to provide sufficient airflow around it to keep it within operational temperature ranges. In situations where the space is confined, or the driver is required to work in extreme conditions, the addition of a fan to blow air across the heatsink may be necessary to keep the driver at a working temperature.

Tuning Connection

To tune the drive a serial connection is required to the PC on which the software is installed, this can be via either the PS/2 socket or through pins 1 & 2 of the control cable. A serial 'dongle' is available from your supplier to convert the high RS232 voltage levels to the TTL levels required on the drive. Two LEDs are also provided as an aid to tuning, LED1 will illuminate so long as the Following Error is within the limit set in the software, LED2 illuminates whenever full power output from the drive is reached. Tuning the drive using the serial software and the on-board LEDs should be sufficient for most applications, however a connection is provided to enable fine tuning the drive with an Oscilloscope, this connector gives a voltage representation of the instantaneous Following Error. Firstly connect the Oscilloscope to the connector as shown in the diagram below.

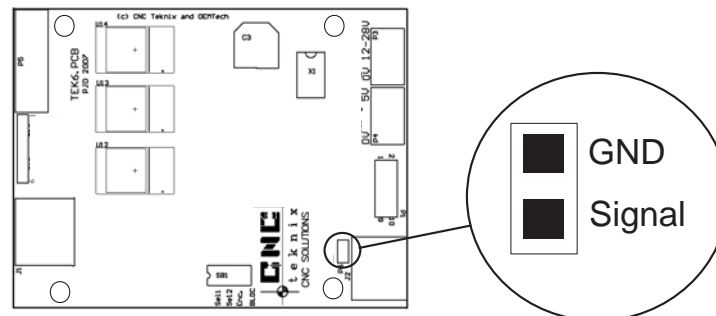

By setting the Oscilloscope display to 500mV per division vertically and 200ms per division horizontally the change in following error can be seen when the drive is commanded to accelerate or decelerate. The maximum output from this connector is 3.2V, or +/-1.6V, (zero following error produces 1.6V) and is proportional to the Max Error setting in the serial software. (+/-1.6V being +/- Max Error value). By adjusting the drive settings via the serial software the motor reaction can be viewed on the Oscilloscope and adjusted to give the optimum response.

Heat Dissipation

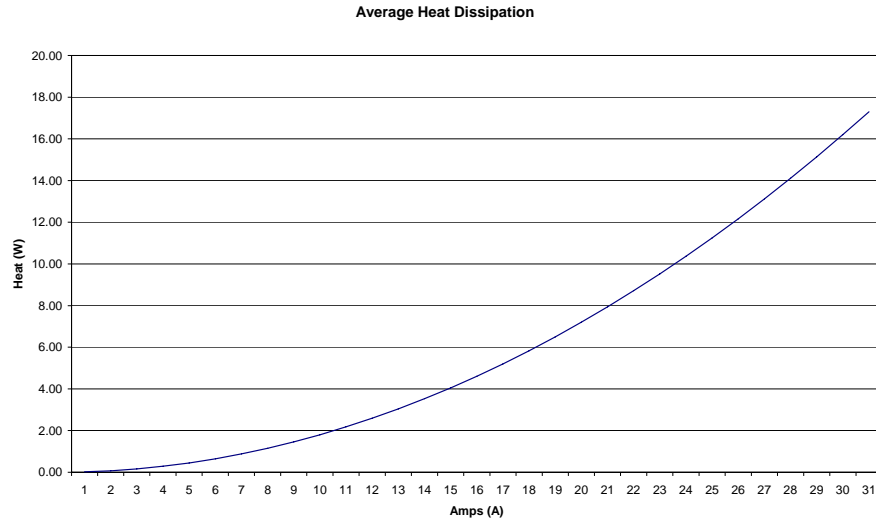

The above chart shows the average heat dissipation for the driver stages of the TEK6 drive. Please note, however, that this is based on a steady state condition and does not take into consideration the inductive or resistive effects of the motor, or the switching effects of the PWM. The tuning of the drive can greatly affect the average current supplied to the motor, if a motor is tuned to be very 'tight' a higher current will be constantly switching back and forth through the coils, this will increase the average current and the heat generation, even though the motor is not moving.

Switch Selections

Two of the user functions of the drive can be selected on the Dipswitch block located near the edge of the drive. Only two of the four switches have a user selectable function, these are:

Switch No.	Label	Functional Description
2		Direction Change, switches the direction of the motor with regard to the input direction signal.
3	Enc	Switches Encoder Polarity. This is to save having to swap the encoder channels should they be wired in reverse to the motor polarity.
4	BLDC	Selects between Brushed and Brushless Motor operation ON = Brushless Motor OFF = Brushed Motor

Drive Safety Features

When used with Brushless DC motors there are two safety features that automatically come into operation, causing the drive to stop immediately in a fault condition. Once the fault has been rectified the drive can be re-enabled.

1. Hall sensor Failure, should any of the Hall Sensor connections fail the drive will fault. This is to prevent damage to the drive due to incorrect switching.
2. Encoder failure, Should either encoder channel fail during operation the drive will fault. This is to prevent the axis from running away out of control that normally occurs with this problem.

Accessories for TEK6

Encoder Adaptors

Single Ended Encoder

Cable	Definition	AMT103-V
1-Brown	CH B	B
2-Red	+5V	5V
3-Orange	CH A	A
4-Yellow	INDEX	X
5-Green	GROUND	G



Sample single ended Encoder

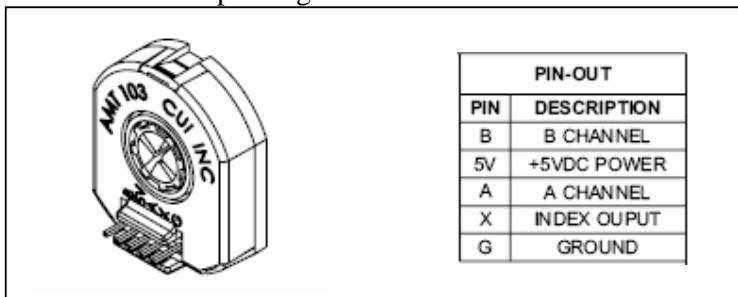

Differential Encoder

IDE-10 Cable	Definition	CAT-5 cable
1	GND	1
2	GND	1
3	-INDEX	3
4	+INDEX	4
5	-CH A	5
6	+CH A	6
7	+5V	2
8	+5V	2
9	-CH B	7
10	+CH B	8



Serial Dongle and Cable

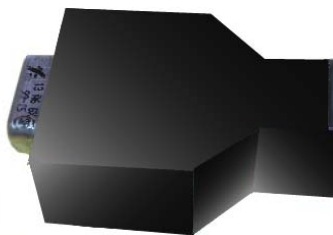

This cable connects the Serial port of the computer to the serial tuning port on the drive, translating voltage levels between the two.. It derives its power from the 5V supply on the drive. For pin signals refer to the connection tables.

Notes



113 Industrial Rd, Oak Flats,
NSW 2529 AUSTRALIA
Tel 02 4257 4111 Fax 02 4257 4811
International +61-2-42574111
Email sales @cncteknix.com
Website www.cncteknix.com