



TEK6

TEKdrive™

Technical & Operations Manual

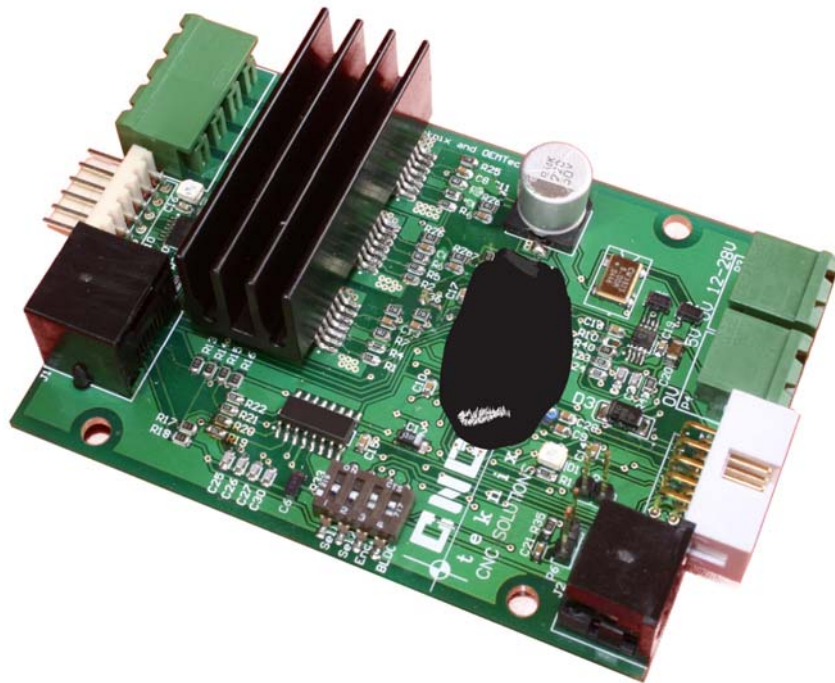

Table of Contents

TEK6	1
TEKDRIVE™	1
FEATURES	5
<i>General</i>	5
<i>Tuning</i>	5
<i>Protection</i>	5
PREFACE	6
PARTS SUPPLIED	6
<hr/>	
QUICK SETUP GUIDE	7
<hr/>	
DESIGN SECTION	8
<hr/>	
D1. INTRODUCTION	8
D2. POWER SUPPLY	8
D2.1 TRANSFORMER VOLTAGE RATING	9
D2.2 TRANSFORMER CURRENT RATING	9
D2.3 RECTIFIER	9
D2.4 CAPACITANCE	9
D2.5 CIRCUIT BREAKER	9
D3. MOTORS	10
D3.1 SIZE	10
D3.2 TORQUE	10
D3.3 POWER	10
D4. ENCODERS	11
D1. RESOLUTION & PPR:	11
<hr/>	
SETUP GUIDELINES	12
<hr/>	
S1. CONNECTION	12
S1.1: INSTALLATION	12
S1.2: LOGIC	12
S1.3 POWER SUPPLY	12
S1.4: ENCODERS	12

S1.5: MOTORS	13
S1.6: CONTROLS & SWITCHES	14
S1.7: SWITCH SELECTIONS	14
S1.8: DRIVE SAFETY FEATURES	14

S2. INTERFACING: 15

S2.1 CONNECTING TO A CONTROLLER:	15
<i>S2.1.1 Hardware Connections</i>	15
<i>S2.1.2 Setting up Controller Software</i>	16
<i>S2.1.3 Axes Resolution</i>	16

POWER ON PROCESSES 17

S3.TURNING ON & TESTING 18

S3.1 TUNING THE DRIVE	19
<i>S3.1.1 Software</i>	19
S3.2 CALIBRATING YOUR DRIVES	22
<i>S3.2.1 Initial Setup</i>	22
<i>S3.2.2: Fine Tuning</i>	22

OPERATIONS SECTION 25

O1. FAULT RESOLUTION 25

O2. MAINTENANCE 26

O2.1: CONTAMINATION CHECKS	26
O2.2: LEAD CHAFFING CHECKS	26
O2.3: MECHANICAL WEAR IMPLICATIONS	26

APPENDIX 1: TECHNICAL SPECIFICATIONS & CHARACTERISTICS 27

I/O DESCRIPTIONS	28
<i>Logic Connector - IDC10</i>	28
<i>5V Logic Supply - Header Terminal</i>	28
<i>12-24V Motor Supply - Header Terminal</i>	28
<i>Hall Sensor - Header Terminal</i>	28
<i>12-24V Motor – Header Terminal</i>	28
<i>PS/2 Serial Terminal</i>	28

O3. SUPPORT 30

NOTES 31

Features

The TEK6 Brushless driver was designed for CNC applications which require a drive capable of speed and accuracy over power, such as small CNC routers, laser engravers, plotters etc. It is capable of delivering 8Amps on a continuous basis, but can deliver peak currents up to 30A when required to accelerate quickly. Its super fast PID algorithm is capable of calculating output power up to 10,000 times per second, which makes it an excellent choice for most modern, light and dynamic Brushless motors, but the loop time is adjustable should a slower motor be fitted. Able to drive Brushed DC and Brushless DC motors with equal ease gives it great versatility, while the serial tuning, LEDs and Oscilloscope output port make it one of the easiest to work with. Following is a description of some of the features of the TEK6:

General

- Drives Brushed or Brushless DC motors, switch selectable
- Fuzzy PID (F-PID) enhanced control.
- Delivers up to 8A continuous current
- Peak current over 30A
- Operates at supply voltages from 12-24VDC
- Speeds in excess of 1MHZ
- Works with single or differential quadrature encoders.
- Encoder channel reversal by dipswitch.
- Minimal Heat Generation

Tuning

- Tuning and Fault indicator LEDs
- Full Serial PID adjustment during operation, either through controller or separate serial cable
- Analogue output of Following Error for visual reference on Oscilloscope.
- Adjustable values for P, I, D, Max Current, Feed Forward, Max Error, Software Loop Time.
- Either Manual or Fuzzy enhanced P, I, D values can be used in any or all combinations.

Protection

- Over Voltage/Temp/Current protection
- Hall Sensor failure protection (Brushless Motors)
- Encoder fault detection (Brushless Motors)
- All Hall sensor and Encoder inputs buffered for spike protection.

If you are unsure how to proceed with a machine design we have included a basic overview of the design process for you to help you get started. If however you are experienced in this we recommend that you jump over the Design section to the more relevant information on setting up the TEK6 in the Setup section on page 12.

Preface

Thank you for purchasing one of our CNC Servo Drivers, we trust that this installation will be an easy procedure for you and that your machine will be up and running very quickly. Please visit our web site, www.cncteknix.com , email our support team technical@cncteknix.com or call us on +61 2 4257411 if you experience difficulties.

Parts Supplied

Upon opening your CNC carton, please ensure that all the following parts are present and undamaged.

- TEK6 Servodrive
- Technical and Operations Manual

If you have ordered any other parts with your driver please ensure they are also enclosed. Contact CNC Teknix **immediately** if parts are missing or appear damaged.

CAUTION!

Your TEKdrive has been pre-tested at the workshop prior to shipping, so it should be pre-set with the basic settings. Please read this manual carefully to ensure it is hooked up correctly before powering it up for the first time.

QUICK SETUP GUIDE

Quick Setup Guide

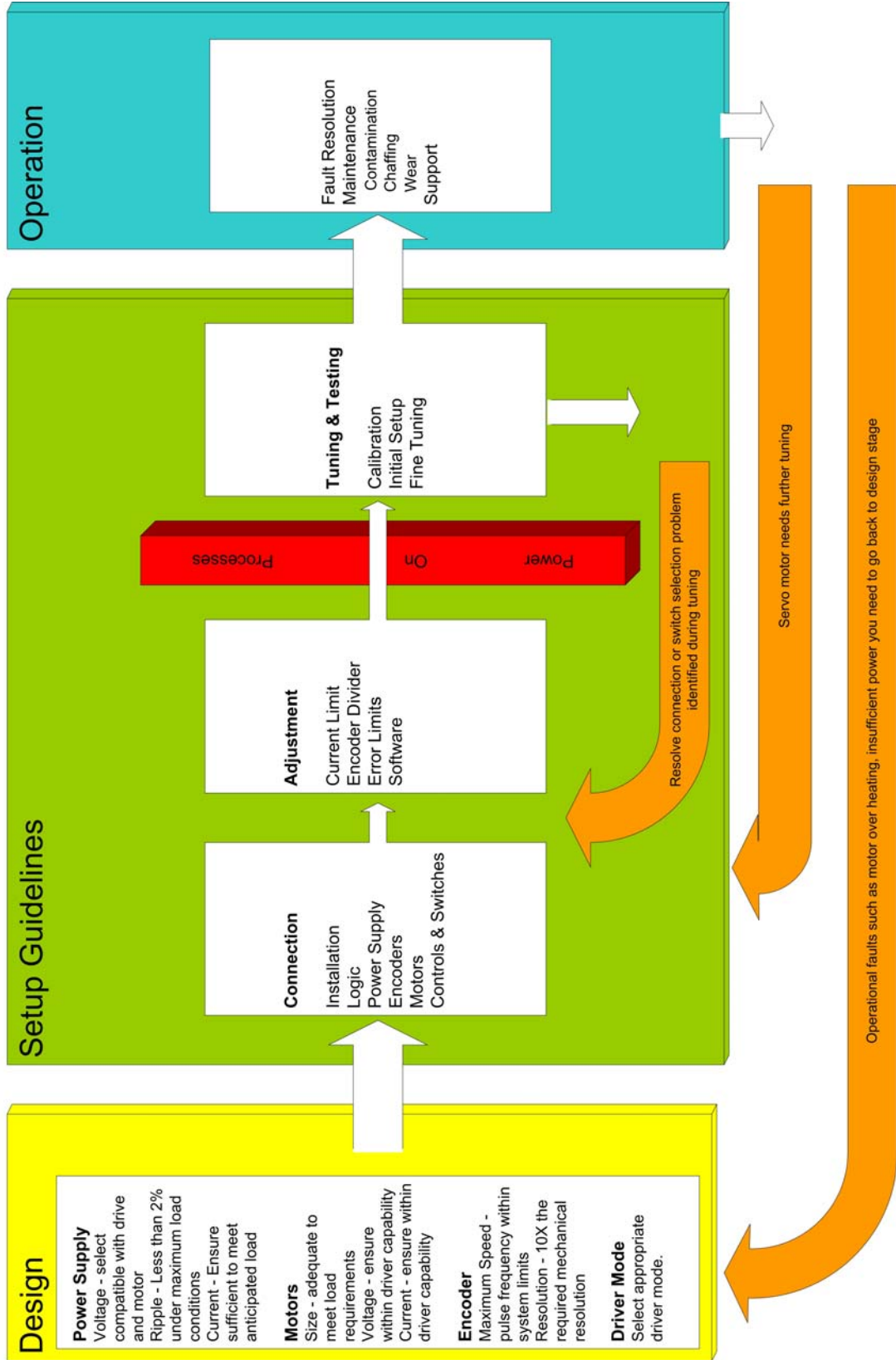

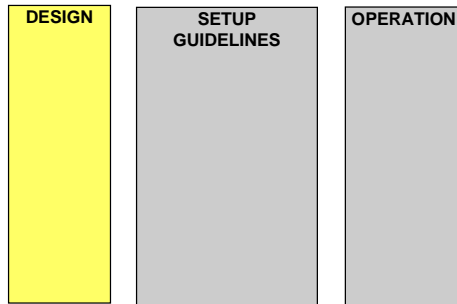

DESIGN SECTION

D1. Introduction

The design of a CNC control system must accommodate many factors. This section of the manual aims to highlight some of the main considerations and outline possible solutions. There are also many resources available on the web which might be helpful during the design phase. In particular the CNCZone.com web site has many links and forums which will assist you in designing your CNC system.

The design phase should (ideally) begin before you purchase anything. In practice you often have some pieces of equipment before you start a CNC conversion. You may have the machine and lead screws or the motors. One purpose of the design phase is to determine how the various pieces will come together in order to build a working system. You may need to go around this loop several times to get it all together. If you determine that bigger motors will be required this may mean a larger power supply etc. If you calculate that you need 325PPR encoders and then find you can only buy 300 or 400 PPR encoders that is fine. You want things in the ball park. The detailed setup of the machine will enable you to fit the as purchased hardware to the controlling software and fine tune the details.

Design is about getting the broad scale of things together. Some experimentation and changes may be required along the way.

D2. Power Supply

To provide power for the motors, connect a power supply with a DC voltage suitable for the motors you are using, and a current output sufficient to power all the motors. The best power supplies for motors include a basic transformer with rectifier and capacitor, switch mode supplies are not always suitable if high current supply is needed due to the fast switching demand of the motor drives.

If you have also purchased your power supply from us it will be correct and ready to connect to the terminals on the side of the driver. If you are planning to build your own the following formulas may prove useful:

D2.1 Transformer Voltage Rating

The transformer should have a secondary output voltage 0.717 times lower than the DC voltage required for the motors, ie. If your motors require 65VDC your transformer secondary voltage should be no more than $65 * 0.717$ or 46.6VAC.

D2.2 Transformer Current Rating

The current rating should be large enough to handle all motors running at full power simultaneously. If you have a 3 axis system with each motor drawing a maximum average current of 10A, then the transformer secondary should be capable of delivering at least 30A. Note that the servo driver has an adjustable peak current limit. Average continuous current will be 20 to 60% below this value depending on your motor, torque and acceleration setup. Conversion of AC to DC does lower this current, as it also raises the voltage, but with a large filter capacitor it should still be sufficient. If in doubt it is better to get a bigger transformer rather than smaller.

D2.3 Rectifier

Rectification can, in most cases, be a standard bridge rectifier, so long as the current rating is not exceeded. If the total current draw is in excess of 25A then it is much better to make up a rectifier using large stud diodes. If you do not have any experience in electronics then it is advisable to seek help in making up this rectifier.

D2.4 Capacitance

The power supply needs enough capacitance to control the ripple voltage to under 2% at maximum load. A capacitance (C1) value of this should be such that it provides at least 1,000uF (2,000uF recommended) of capacity for every 1 Amp of current draw, so if your motors draw a total of 25A then you will need a capacitance of at least 25,000uF. This can be one large capacitor or 2 or more smaller capacitors connected in parallel. Mount the capacitance, power supply, as close to the drivers as possible.

D2.5 Circuit Breaker

The power supply connects directly to the mains thus it is required ,for safety reasons, that you have a circuit breaker in the circuit. You will need one on the input mains supply and another Slow Blow fuse on the output to the driver. Remember to specify to your supplier the DC current rating needed.

WARNING!

The power supply should be connected to the two terminals on the right side of the driver.

ENSURE CORRECT POLARITY.
Severe damage will result if it is connected incorrectly.

CAUTION!

Ensure the negative line is the same potential as the logic negative supply.

D3. Motors

D3.1 Size

The motors must be able to generate sufficient torque to overcome friction in turning the lead screw. The cutting load will apply additional torque requirements to the lead screw. The exact load depends on the lead and design of the nut. Torque available above these requirements is required to accelerate the motor and overcome inertia of the lead screw and attached mass. Torque must be greater than the load at all speeds below maximum. Excess torque above the load is available for acceleration. The higher the excess torque the greater the acceleration available. Reduction gearing decreases the motor torque requirements and inertia ratio. Exact calculation of the torque requirement is a specialised activity beyond the scope of this manual.

D3.2 Torque

Estimating the torque requirement can be achieved by using a lever and weight to determine the starting torque required to begin rotation. Keep in mind that much of the inertia in a typical machine is from the ROTATING mass of the ballscrew, coupling, bearings, and the armature of the motor itself. The sliding (linear) mass has inertia too, but you'll probably find that the rotating (polar moment) inertia is the big factor. The rotating masses, including the motor armature, act like a flywheel which takes significant energy to accelerate and decelerate. The largest load however is the friction of the moving components, the friction of the sliding mass is usually the greatest but its effect is significantly reduced due to the reducing or gearing action of the screw that moves it.

D3.3 Power

The motor must also be able to handle the average power input without overloading thermally. As some part programs may take several hours to complete the thermal load on the motor will cause excessive heating if the motor is not able to dissipate the heat. Check the continuous power rating of the motor is not exceeded.

A higher power motor may draw more current than the servo driver can supply under certain load conditions. Peak current for a brushed DC motor occurs when the motor is at maximum acceleration. A 300W, 24 Volt motor may be rated at 12.5Amps continuous but may draw 30 plus Amps with the motor accelerating a load. This condition may occur at start up depending on the acceleration settings and inertia of the drive system.

D4. Encoders

D1. Resolution & PPR:

The driver requires quadrature encoder feedback to control the servo motor. Encoders have two channels and are available with different resolutions. On a quadrature encoder each channel generates a given number of PPR (Pulses Per Revolution). The TEKdrive counts each transition of each of the channels, so the effective resolution is four times the given resolution. Select an encoder with the appropriate PPR for your system. The PPR count affects the resolution and speed of the system. Resolution can be calculated as follows:

$$\text{Linear Resolution} = \text{pitch lead screw} / ((\text{PPR} * 4) * \text{Drive Ratio})$$

For example if you had 5mm per turn lead screws, 1200PPR encoders and 3:1 drive ratio the resolution would be:

$$\text{Linear Resolution} = 5 / ((1200 * 4) * 3) = 0.000347 \text{mm/step}$$

As a general rule, a resolution of 0.00035mm will deliver an effective resolution of 10 times larger. So this system would perform to a working resolution of approximately 0.003mm or 0.00012 thousands of an inch.

The resolution of the encoder also affects the maximum speed of the motor. The servo driver must be able to read the encoder pulses and the driver must be able to generate enough Step pulses. Using the above example, 1200 PPR encoder at 600RPM requires a pulse rate of 48Khz giving a linear velocity of 3000mm per minute. (Encoder resolution * 4 * RPM). For most PC based direct drivers this would be the maximum pulse rate. The TEK6 can accept pulses at up to 1Mhz, giving a maximum speed for the above motor of 12,500RPM, and this configuration a linear velocity of 62.5M per minute. (See Driver Specification-appendix 1 for details) Higher pulse frequencies sustain high maximum speeds and higher resolution.

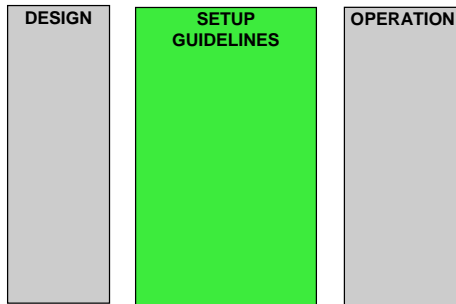

SETUP GUIDELINES

S1. Connection

S1.1: Installation

Before connecting any wires to the TEKdrive please ensure that the mounting position will dissipate the required amount of heat from the driver for your application. See technical datasheet for full specifications. Also ensure that it is not in a place where it can get splashed by coolant or covered in shavings from the machine.

S1.2: Logic

The TEKdrive control uses Step and Direction signals to control the motor. Each pulse on the step input moves the motor a specific small increment as defined by the encoder resolution, gear ratio and screw lead. The direction of the rotation is determined from the logic state of the Direction input. For details of the connections please refer to Appendix 2.

S1.3 Power Supply

In the design section, you determined the appropriate power supply that would need to operate all the servo motors you are connecting to the TEKdrive. Connect the power supply ensuring that the polarity of the connection is correct. Ensure the power supply is appropriately positioned to be clear of swarf and coolant contamination. Position the power supply as close as possible to the driver.

S1.4: Encoders

Either single ended or differential encoders can be used with the TEKdrive, differential encoders being recommended due to their increased resistance to noise. The Encoders are connected via the large RJ45 connector and accepts a standard computer network style connector, any standard computer patch cable can be used, which makes connection to the drive very simple. The pinout of the connector is detailed in Appendix 1, but if a standard computer patch cable is used there are connector adaptors available for connecting the patch cable to the encoder.

It is important that the polarity of the 5V and Gnd terminals are connected correctly, however the ChA and ChB can be reversed without any adverse effects. Reversal is also possible through the on-board dipswitches.

WARNING!
Do not connect the encoder shield to the motor shield.

S1.5: Motors

Brushed DC Servomotors have two leads for connecting the power, these are usually coloured red and black, but the colour is not very important. If these are connected the wrong way no damage will result, the motor will just travel in the wrong direction. Brushless DC motors have three wires, usually termed U, V & W, as well as three Hall effect sensors similarly termed to feed back the rotor position information. The cable you use to connect the motor to the driver should be shielded and large enough to carry the current needed by the motor. At the motor end the shield in the cable should be connected to the motor case, and at the driver end it should be connected to the chassis ground, through terminal 4 of the motor connector. It is used to ensure all motors remain at the same electrical potential as the driver.

Brushless Motor Connections

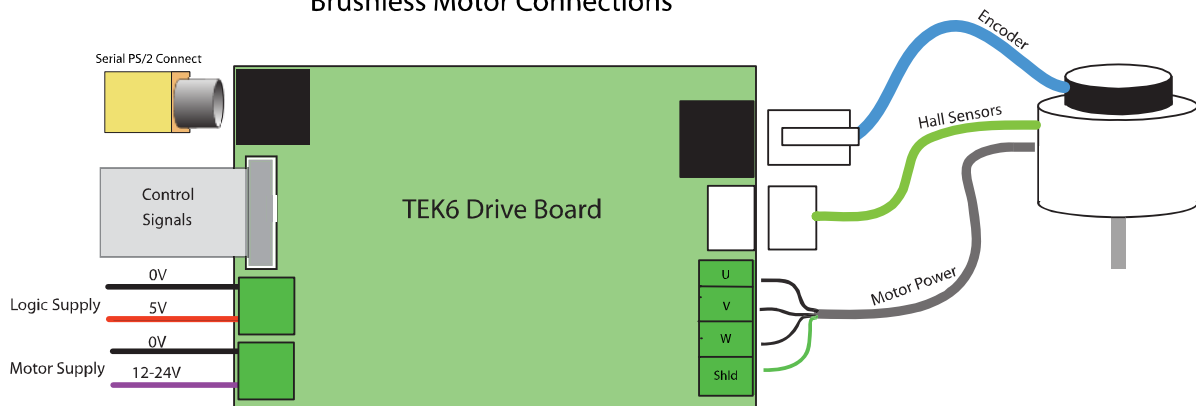

Brushed Motor Connections

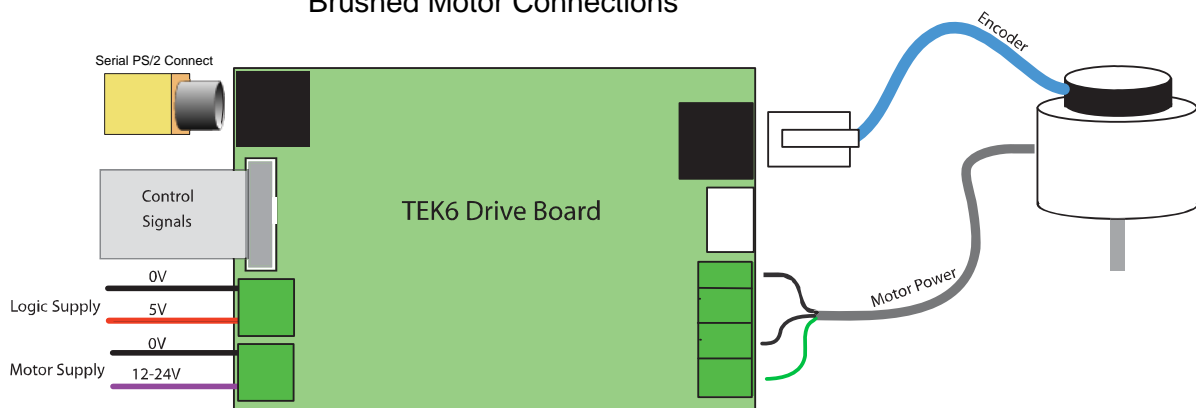

S1.6: Controls & Switches

Limit and emergency stop switches should be connected from the machine to the controller or PC. Limit and/or emergency stop signals could be used by the controller logic to disable the driver under conditions where further motor rotation would cause damage or potential injury. The RUN signal from the driver can be used by the controller to detect driver faults caused by position error or over current limits. If a single driver faults then the controller should command an emergency stop to halt all motion, as further motion of the remaining axis could cause damage to the machine or job.

S1.7: Switch Selections

Two of the user functions of the drive can be selected on the Dipswitch block located near the edge of the drive. Only two of the four switches have a user selectable function, these are:

Switch No.	Label	Functional Description
2		Direction Change. Swaps the direction the motor will move for a given direction command.
3	Enc	Switches Encoder Polarity. This is to save having to swap the encoder channels should they be wired in reverse to the motor polarity.
4	BLDC	Selects between Brushed and Brushless Motor operation ON = Brushless Motor OFF = Brushed Motor

S1.8: Drive Safety Features

When used with Brushless DC motors there are two safety features that automatically come into operation, causing the drive to stop immediately in a fault condition. Once the fault has been rectified the drive can be re-enabled.

- Hall sensor Failure, should any of the Hall Sensor connections fail the drive will fault. This is to prevent damage to the drive due to incorrect switching.
- Encoder failure, Should either encoder channel fail during operation the drive will fault. This is to prevent the axis from running away out of control that normally occurs with this problem.

S2. Interfacing:

S2.1 Connecting to a Controller:

S2.1.1 Hardware Connections

The 10 way IDC connector is a single “plug in” connection for all the control and feedback connections to the controller, these include the Step and Direction inputs for the movement, Enable and Run signals for main On/Off control, RX and TX signals for communication as well as the ChA and ChB signals direct from the motor encoder. As previously mentioned, the drive accepts Step and Direction signals to control the movement. This makes the drive compatible with most stepper motor control systems. However, unlike Stepper motors that are always powered on, Servo motors need to be enabled or “Locked On” to start or reset after a fault. They also send back a status signal to the controller to confirm that it is working within its parameters. If a stepper motor is stepped too fast, or it meets an obstacle, it will “Miss-step” and continue on an incorrect path. Servo motors however have a feedback so it can tell exactly where the motor is, and, if it loses its position for any reason, it will stop rather than carry on and destroy the workpiece. The controller needs to be able to monitor this signal and stop the operation should a fault occur.

To handle this, the drive has an ENABLE input and a RUN output, so long as the ENABLE input is set to 5V the drive will stay on and engaged, it will also set a logic high on the RUN output. If the drive trips the RUN output will go low to tell the controller it has stopped. To enable the drive again the ENABLE signal must be turned off and back on again. If a drive trips and stops it is good practise to ensure that all the other drives on the machine stop as well, a simple way to achieve this is to use all the RUN signals from the drives to latch on the ENABLE signals, so that if any drive sets its RUN output low it will automatically turn off all the ENABLE signals to all the drives. A simple circuit could look like this:

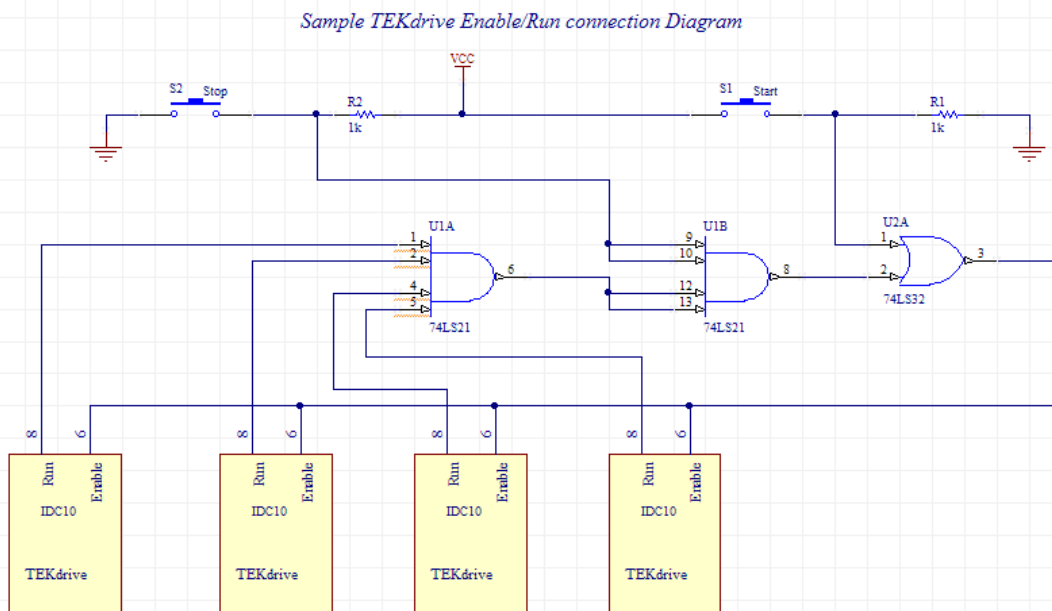

Also in the control cable connector there are two connectors which send back the motor encoder signals, this can be used by the controller to closely monitor the actual position of the motor. This feature was added to assist in applications where synchronisation of external equipment to the actual motor position is required.

Pins 1 & 2 of the control connector are used for the serial communications to the drive for setting the PID adjustments. These signals are serial in nature but operate at logic levels only, not +/-12V as in a true serial port connection. **Do Not connect a computer serial port directly to these terminals.**

S2.1.2 Setting up Controller Software

The controller software generally runs on a PC under and may control the driver directly via the parallel port or through Embedded motion control card connected to the Serial or USB ports. The embedded controllers have the advantage of providing much higher pulse frequencies to the drives.

Before use the control software needs to be given the parameters of the drive and the motor, this includes the number of steps it needs to send out to move the machine the correct distance, and the maximum acceleration and speed it can tolerate. These are described below.

S2.1.3 Axes Resolution

To determine the resolution (in step pulses/mm) you can make an approximation using the formula (Encoder resolution * 4)/Distance travelled, where Distance travelled is the movement of the axis for one rotation of the motor shaft. As an example, a motor with a 1000ppr encoder direct driving a 5mm pitch ball screw would be:

$$(1000 * 4) / 5 = 800 \text{ steps/mm}$$

Finally specify the maximum speed of the motor can be approximated from the last equation by taking the steps/revolution (encoder * 4), which is the number of pulses for one rotation of the motor shaft. This is also the number of pulses to generate a speed of 1 RPS, or 60rpm. If you have a motor with a max speed of 3000rpm then the pulses needed to drive it would be 3000/60 (to get rev. per sec.) (in this case 50) *steps per rev. If you have an encoder of 500ppr it takes 2000 steps for one rotation, therefore 2,000 * 50 = 100,000 steps/sec.

If you prefer to calculate the linear speed of the axis instead, take the Steps/mm figure and multiply it by the number of mm travel per second you want it to move. For example, using the above encoder at 800steps/mm, for 100mm/sec travel (6M/min) 100 * 800 = 80,000 steps/sec. You should also be able to set the acceleration for each axis. Some controllers have a single acceleration setting and others have a more comprehensive acceleration profile system. Acceleration settings will be important during the tuning phase of the setup. Reviewing your controller setup documentation before powering up the servo driver will assist you in setting up and tuning the servo driver.

POWER ON PROCESSES

WARNING!

Use of high voltage DC power supplies can pose a potentially lethal danger. Ensure all power leads are correctly insulated and firmly connected.

Confirm power connections are correct:

1. Polarities of all connections are correct.
2. Check polarity of any electrolytic capacitors you have used to control ripple on the motor power.
3. Ensure no connections or wiring can short to each other or ground.
4. Earth connections are made from the power socket to chassis and machine.
5. The correct fuse and/or circuit breakers are in place.
6. Switch 4 (BLDC) on switch selector block is set for the correct motor type, Brushed or Brushless motor. Incorrect selection could damage the drive.
7. Once you have confirmed that the wiring of the machine and driver is correct you can get ready to power it up.

You may need to turn on your controller software to provide the enable input to the drives. Once the enable signal is active and the drive 'locks on' the drives LED will stop flashing and stay illuminated. If this does not happen please check all connections to the drive, especially the Motor Hall sensor and Encoder connections, as fault detection circuitry on the drive will prevent the drive from starting if it is not correct.

CAUTION!

Incorrect connection of power supplies can cause serious damage to the TEKdrive.

S3.Turning on & Testing

Firstly you need to determine if the axes are moving in the right direction. To visualise which is the right direction, imagine the table as a piece of graph paper with the zero point of the X and Y in the bottom left corner. As with any standard graph the Y axis increases as it goes up the page and the X increases as it goes to the right. To draw a line on the paper the pen (tool) has to move across the paper, for an increase in X the pen moves to the right (or the table to the left).

Turn on the power supply. It is normal for the servo motor to hiss slightly when everything is hooked up correctly. The motor is dithering at high speed between adjacent encoder counts. The integral function in a PID loop has infinite DC gain over time and will amplify even the smallest position error. Because quadrature encoder feedback only occurs on the edge of a line, no count is encountered until the servo moves enough for an edge to pass the sensor. The TEKdrive then reverses the motor direction until another edge is found dithering the motor between the two edges. If the motor jumps slightly and the drive trips out, then probably either the motor or the encoder are wired backwards. Change the position of switch 3 on the switch block and engage the drive again.

To check the direction of your axes first press the X+ jog button, focusing on the tool it should move across the table as if to draw an X+ line on the table, travelling to the right. Pressing the Y+ jog button should move the tool towards the back of the table, The Z axis should move up on a Z+ jog and down on a Z- jog. If any of these jogs move the table in the wrong direction it can be corrected in the control software.

Finally you will need to check the calibration, or the accuracy of movement. A dial indicator is very useful for this but reasonable results can be achieved with a good ruler. To do this you need to zero the axis for calibration close to one end of its travel and make a mark at that point. Then move the axis to a point a fixed distance close to the other end of the travel and make another mark. If there is any difference between the displayed and the measured distance you will need to change the steps/mm setting in the control software. To calculate the correct value, use the following equation:

$$\frac{\text{Displayed Distance}}{\text{Measured Distance}} * \text{present Steps/mm setting}$$

As an example, with a steps/mm setting of 400, if the X axis is moved 90mm according to the screen display, and the measured move is 100mm, then the correct setting is $(90/100)*400 = 0.9 * 400 = 360\text{steps/mm}$.

You should now have your machine running accurately with the axis directions correct. There are many more settings that can be adjusted or tweaked to better the performance of the machine, but these will not be described here as they are specific to your particular controller software. Please review your controller documentation to set items such as axis acceleration and maximum velocity.

S3.1 Tuning the Drive

S3.1.1 Software

On starting the software the screen will look like this:

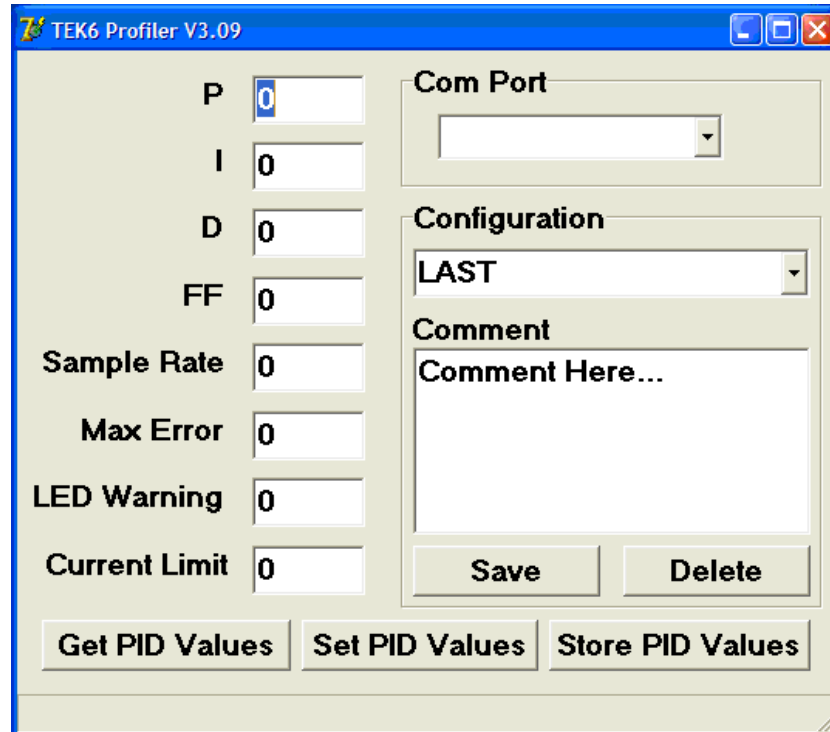

First select the serial port to which the serial Dongle is connected. Pressing the “Get PID Values” button will retrieve the values currently set in the drive. If this does not happen, check the troubleshooting guide in the back of this manual. Changing any of the values in the window boxes and pressing “Set PID Values” button will send these values down to the drive where they will be implemented immediately. Use this to experiment with the settings until the best settings are found. Pressing “Save PID Values” button will then store these values into its Flash memory, from where they will be loaded every time the drive is turned on. There is virtually no limit to the number of times these values can be changed or saved.

Should you wish to retain the settings on your computer for future use you can give them a name, ie. ‘X Axis’ in the Configuration window, add a descriptive comment in the comment box if required, and click the “Save” button immediately under the Comment box. There is no limit to the number of different configurations you can save for future use, old or unwanted configurations can also be deleted to avoid confusion. Should you then wish to program an identical drive at a later date you can select the settings you want in the “configuration” window and send it to the drive as described above.

Setting Descriptions:

P Proportional: This is the amount of power, relative to the error, that the drive will output. The analogy here is a comparison to the accelerator in a car, if you are travelling at 60Km/H and you want to travel at 80Km/H, the P controls how much more the accelerator needs to be pushed to get the right speed. If the P is set too low it will accelerate very slowly or trip out on a following error, too high and it will likely speed up too quickly and overshoot, causing it to have to decelerate again. This can cause the drive to oscillate, and, if set too high, will cause ever increasing oscillations until the drive trips out.

I Integral: This is often called the steady state error compensation gain. If there is a small error, not enough to cause the P control to correct, but present for a period of time, the I adds up (Integrates) all these errors over a time period and causes the drive to adjust to reduce this error. If this is set too low it will take longer to reach the desired position, if too large it can cause oscillations in the drive output.

D Derivative: This is the adjustment for the 'rate of change' error, such as when a sudden acceleration or deceleration is called for, or the load quickly changes. It works by adding or subtracting power to assist the correction for any sudden changes. Back to the car analogy, if the car was to suddenly reach an incline and the speed starts to decrease it looks at how fast the car is slowing down and adds a burst of power to correct for it. As it acts faster than the proportional control it is also helpful in decreasing the oscillations caused by too much proportional control.

FF Feed Forward: Is a setting to say how much of the original input signal is sent straight through to the drive. Normally the PID handles the output power to keep the motor in the correct position, but in cases where high acceleration is needed it is better if the drive can monitor the frequency of the input pulses and directly output a portion of the power required. This makes for faster acceleration and reduces the PID to fine tuning on the remaining error.

Sample Rate This setting allows for adjustment to the PID loop time in the drive. On systems where a light or dynamic motor is used, the reaction time of the drive needs to be relatively quick, whereas a heavy or sluggish motor will do better with a much slower reaction time. To achieve this it is possible to change the number of times the PID algorithm is executed in each second. Starting with a 25KHz base frequency, dividing it by the number entered into this box (+1) will give the number of calculations. As an example, with a value of 2 entered the calculations would be $25,000/(2+1) = 8,333$ calculations/sec., with a value of 15 there will be $25,000/16$ or 1,562 calculations/sec. Any value between 2 and 15 may be used.

MAX Error: Is the maximum error you will allow for this drive. Should the Following Error exceed this value for a period of greater than 50 milliseconds, the drive will trip with a Following Error fault. This value also acts to scale the output for the Oscilloscope tuning, setting the maximum voltage on the output to this error value. Keeping this error only marginally above the operating maximum of the drive will give a good indication if problems are developing in the machine.

LED Warning: Sets the following error limits, within which the LED on the drive will remain illuminated. This can be very useful in tuning the drive as setting it to a value close to the steady state error you expect, say in the range 5 – 10, it can be clearly seen how long the drive takes to recover position after an acceleration or deceleration. A further description of this LED follows.

Current Limit: A setting for the maximum continuous current, this can be any whole number in the range 1 – 100 and represents the current in 0.1A increments. For example, a setting of 65 would be a current limit of 6.5A etc. The current limiting does not come into effect until this preset limit has been exceeded for 0.5 seconds, after which time it reduces the output power to the limit. This gives enough time for the initial current surge for a fast acceleration but protects the motor against continuous high currents. Should the drive be unable to maintain its positional accuracy with the current reduction it will trip out with a following error, however in this case LED2 will also remain lit to indicate the current limitation was in force. Setting a value of 0 removes the current limit feature, but **this is not recommended for normal usage as it can lead to damage to the drive and/or motor.**

Setting	Range	Description
P	1 - 2000	Proportional Control
I	1 - 500	Integral Control
D	1 - 100	Derivative Control
FF	1 - 100	Feed Forward Control
Sample Rate	2 - 15	PID Calculations/sec (= 25,000/Sample Rate+1)
Max Error	1 - 2000	Following Error Limit.
LED Warning	1 – Max Error	LED1 on drive ON while within +/- LED Warning
Current Limit	1 - 100	0.1 – 10A Cont. Limit, (input in 0.1V increments)

Table of Input Limits

S3.1.2 Indicator LED

There is an LED on the TEKdrive which indicates the present state of the drive and can help with the tuning process. If the LED is on, off or flashing it has a different meaning. The status of the drive can be determined from the following:

LED Action	Description
Flashing 1/sec	Drive disabled
Flashing 2/sec	Drive tripped on Following Error (or Over-current if LED2 is also on.)
Flashing 4/sec	Wiring failure in Encoder or Hall sensors (BLDC mode only)
On Steady	Drive on and within specified Following Error, Normal Operation
Off	Drive on but Following Error exceeds specified limit

S3.2 Calibrating your Drives

To calibrate the drives you will need the serial software installed on your computer and a serial dongle and cable connected from the serial port to the PS/2 connector on the Drive. Ensure you are using the dongle supplied by your distributor as these are purpose built for this application. Use of any other form of dongle may prove fatal to the drive.

S3.2.1 Initial Setup

To get your drives operational prior to fine tuning you can follow this guide.

1. Set up the PID settings to a minimum, preferably set the P to a low value and set the I and D to 0.
2. Set the Max Following error to 2000.
3. Set the Feed Forward to 30 and Sample Rate to 4.
4. Click on the "SET PID VALUES" button
5. Enable the drive.
6. Try turning the motor shaft by hand. If it suddenly spins off and trips, the motor and encoder are working in opposite directions. Flip switch 3 on the dipswitch block on the drive to reverse Channels A and B in the encoder.
7. If the motor shaft "Locks on" but the shaft can be turned easily, gradually increase the P. Do this until the drive starts to become unstable or vibrates, then back it off a little.
8. Increase the D until the step movements feel nice and solid. If this is adjusted too far the motors can produce a 'hissing' sound, if this occurs back it off a little.
9. While slowly hand-turning the shaft of the motor back and forward, adjust the I pot until little or no 'slop' can be felt.

Your TEKdrive should now be adjusted fairly close to the correct settings. If during operation you find it trips out with a positional error on acceleration you might need to adjust the P or the D up a little. For this you might also consider setting the Max Error to a larger value. Alternatively you should adjust the acceleration settings in your controller software to ensure a slower acceleration. These settings can be improved using the on-board LEDs, set the LED Warning to a lower value and jog the axis, the settings can now be adjusted to improve the 'recovery' time after a move, or the steady state error, by monitoring the LED. Ensure the motor does not vibrate when at rest, this greatly increases current draw and can overheat the drive. LED2 is provided as an indication of max power output, ensure this turns on only rarely on acceleration

S3.2.2: Fine Tuning

Provision has been made on our TEKdrives for you to optionally fine-tune them with an Oscilloscope. To do this you will need an Oscilloscope and a cable which will connect it to the socket on the drive (just near the PS/2 Serial connector, see diagram.). This output represents the Following Error and swings between 0 and 3.2V, with 1.6V being the 0 error point. Following is the sequence for tuning the drives:

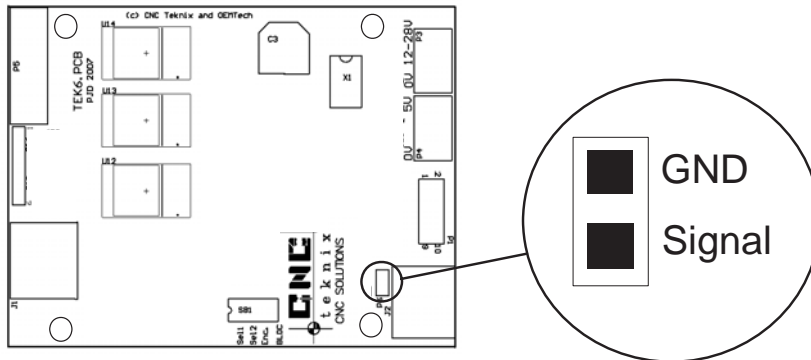

1. Set the Max Error in the tuning software to a value close to the maximum you expect it to reach, The trace on the Oscilloscope is scaled to the Max Error value in the software, so that if the error is set to 1000 the trace will reach its maximum values at an error count of +/-1000.
2. Engage the drive.
3. Set the Oscilloscope scales to an initial value to see the output. Normally this would be 500mSec/Div on time and 200mV/Div on Voltage.
4. Set the jog speed to a fast setting and jog the selected axis backwards and forwards repeatedly over a short distance, say 10mm. You need to set the drive to quickly accelerate and decelerate the motor so you can see how it responds. On each start/stop/direction change you should see a sharp deviation from the zero with a steady ramp back to the line.
5. If the trace on the scope goes off the screen and the drive trips, increase the Max Error value in the software, conversely, if the trace is very small, reduce the Max Error.
6. While watching the Oscilloscope display, adjusting the P will increase or decrease the peaks that occur when the drive stops or changes direction. Adjust the P to get the smallest peak but the minimum of ripple as it recovers. If the P is too large there will be large ripples whenever the motor position is disturbed. If you get a series of oscillations after each direction change, then back it off a little.
7. Adjust the D to reduce the oscillations even further, you will see an increase in the 'noise' of the signal when you increase the D, try to find the happy balance between the bounce and the noise. The ideal signal should have one to two oscillations before settling to the new value. In cases where there is a high inertial load, or flex in the drive system this may not be possible, in these cases tune it to get the lowest oscillations. Reducing the acceleration in the controlling software can also help greatly in these cases.
8. Adjust the I pot so that the signal returns to the line relatively quickly without causing any further oscillations. Set too low the signal will return slowly, too fast and it will overshoot the line and go into oscillations.

9. To see exactly how big the error really is, stop the program and turn the P back to the zero position (after remembering what it was!) to remove all power from the drive. Moving the shaft by hand until the signal deviates to the same level as you saw in the last step will show you how big the error is at its worst case.

K_P too small.

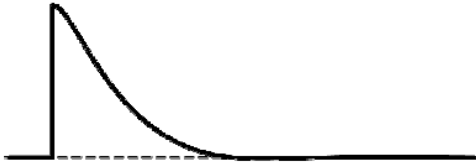

K_I too small.

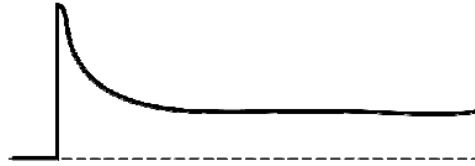

K_D too small.

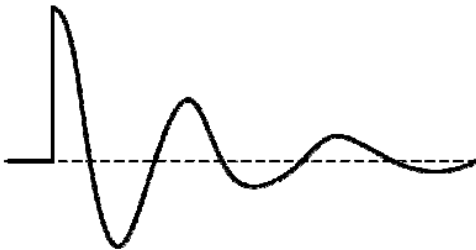

Correct K_P , K_I and K_D .



Typical graphs of Following Error as displayed on the Oscilloscope.

Your TEKdrive should now be fully tuned and running your machine to its best ability. Should you have any problems following the tuning steps above please do not hesitate to call us and we will be glad to help you.

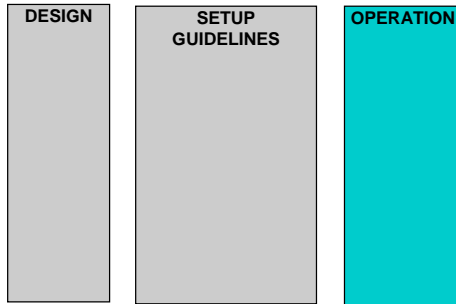

OPERATIONS SECTION

O1. Fault Resolution

During operation there are several faults that will cause the drive to fault. The drives can trip out from a position error, over-current, over temperature, Hall sensor failure or Encoder channel failure. The on-board LEDs give an indication of the reason for the trip should one occur. The first of these errors is the result of the drive being unable to move the servo motor to the correct position within the user-set error limitations. A position error fault is a direct indication of this condition. An over-current trip occurs when the drive increases the current to the motor to correct for the error and this then exceeds the current limitation of the drive. The software will automatically reduce the current should this situation occur, but should that not have the desired result a trip will occur. Assuming that the drives were tuned during the initial setup of the system and the system has been operating for some time without fault indications. A fault condition could be caused by the following factors:

1. Increased cutting load due to tool wear, higher feed rate, or vibration.
2. Electrical wiring faults to motors and encoders. Loose connections, chaffed wiring.
3. Changes to the controlling software have affected the acceleration profiles of the system.
4. Change in moving mass due to large job mass, fixtures and clamps
5. Changes in lubrication or adjustment of mechanical components for the system
6. Wear in mechanical components. Such as gear boxes, ways, lead screw and nut.
7. Motor performance decreased due to worn or dirty brushes.
8. Dirt or light entering encoder housing causing errors in reading

After investigating these factors and the fault continues to re-occur, return to the Set Up Guidelines – Tuning and Testing section and re tune the drives.

Other problems may only become apparent following a period of operation. Often these develop as the use of the machine is expanded and its operational envelope is explored. This could include motors over heating, or being under powered. At this point you have two choices. You can work within the limitations or go back to the design phase and modify the system. For example you may find that by changing or adding reduction gears you can trade maximum speed for more torque.

02. Maintenance

Include the following three areas in your routine machine maintenance tasks to ensure continued reliable performance of your CNC driver.

02.1: Contamination Checks

The TEKdrive may become contaminated by swarf, coolant and dust build up during normal operation. Locate the TEKdrive such that swarf does not collect on or around the unit. Shields and covers may need to be fabricated and installed to control swarf build up once in operation. Coolant should not come in contact with the driver or flow under it at any time. Steps should be taken to clean and eliminate coolant contamination if this occurs during operation of the machine. Fan forced cooling air will cause dust to build up around the TEKdrive.

02.2: Lead Chaffing Checks

In many applications the motors and encoders are attached to moving parts of the machine. During operation, the motor power and encoder leads flex back and forth thousands of times. Machine vibrations during cutting can cause deterioration of cables and connections. All cables and connectors from the driver to the machine should be checked for signs of wear. Any cables with signs of wear should be replaced and alternate routing or support designs investigated.

02.3: Mechanical Wear Implications

The tuning of the drives aims to match the TEKdrive to the motion system, mechanical load and inertia. As the mechanical system wears, the forces may change and require adjustment of the servo driver control settings. Lubrication of the mechanical system should be applied to reduce this occurrence. Adjustment of gibs and ways should be conducted with care, and any major adjustments may require concurrent servo tuning. Many software control applications have backlash compensation to account for the measured backlash of the system. Over time, mechanical wear can change the backlash and may necessitate the adjustment of the software. Play can develop in the screws which will affect the accuracy of the motion system. As maintenance is done to the mechanical system be aware that it may have implications for the control system and require re-adjustment or calibration of some elements of the driver.

Appendix 1: Technical Specifications & Characteristics

Parameter	TEK6
Drive Specification	
Drive Voltage (Maximum)	28V,
Drive Voltage (Minimum)	12V,
Drive Voltage Ripple	<2% See Note 1
Drive Current (Peak) [Software Limited]	30A,
Drive Current (Continuous)	8A,
Drive Current Trip Value	30A,
Drive Current Trip Time	500mSec,
Servo Motor Resistance (Minimum)	1 ohm
Servo Motor Inductance (Minimum)	1mH
PWM Switch Frequency	25Khz
Logic Specification	
5V Logic Supply	5V @ 85mA
24V Driver Supply	24V @ 8A
Logic Level	3.3V – 5V TTL
Encoder Quadrature TTL Channels	2
Encoder Current (Maximum)	200mA
Encoder Pulse Frequency (Maximum)	1Mhz
Encoder following error trip	+/- 10 to +/- 2000 selectable
Encoder Voltage	5V +/- 10% 0.25A Maximum current draw
Physical Specification	
Dimensions	67mm (W) 26mm(H) 90mm(L) 2.63in (W) 1.02(H) 3.54 in(L)
Weight	42gms or 1.475oz
Mounting Hole Diameter	3.2mm
Motor / Power Terminals	Plug Header 15A
Hall Sensor	6 way Header 0.1"
Logic Connector	IDC10
Encoder Connector	RJ45
Operating Temperature Range	0 ~ 55 DegC RH 90% non condensing
Storage Temperature Range	-30 ~ 85 DegC RH 90% non condensing
Vibration/Shock Resistance	0.5/2G
Thermal Resistance	0.165R @ 80degC
Thermal Heat Dissipation (Maximum)	90W

I/O Descriptions

Logic Connector - IDC10			
Pin	Label	Description	
1	RX	Input – Serial (5V logic) RX connection for the tuning software.	
2	TX	Output - Serial (5V logic) TX connection for the tuning software.	
3	STEP	Input – The rising edge of the step input commands a single encoder step rotation in the direction selected by DIR.	
4	DIR	Input – A logic high selects a clockwise step and logic low a counter clockwise step.	
5	ChA	Output – Re-transmission of the encoder Channel A signal to the controller.	
6	ENABLE	Input – Logic high enables the driver to control the servo motor. Logic low stops all output to the servo motor.	
7	ChB	Output – Re-transmission of the encoder Channel B signal to the controller.	
8	RUN	Output – Logic high output indicating the drive is running correctly. If the drive is ENABLE and an error occurs the RUN output will indicate logic low.	
9/10	GND	Logic ground connection.	
Encoder Connector - RJ45 Connector			
Pin	Label	Description	
1	GND	Signal ground to encoder	
2	+5V	5V supply to encoder	
3/4	N/C		
5	CHA-	-Input of encoder channel A (Leave unconnected with single ended encoders)	
6	CHA	+ Input of encoder channel A	
7	CHB-	- Input of encoder channel B (Leave unconnected with single ended encoders)	
8	CHB	+ Input of encoder channel B	
	NOTE	Max voltage for any of the signal pins (3-8) is 15VDC (with external supply)	
5V Logic Supply - Header Terminal			
Pin	Label	Description	
1	-	0V logic supply Gnd	
2	+	5V logic supply positive.	
12-24V Motor Supply - Header Terminal			
Pin	Label	Description	
1	-	0V Motor Power Supply	
2	+	12-24V Motor Power Supply	
Hall Sensor - Header Terminal			
Pin	Label	Description	
1		Cable Shield Gnd	
2		0V logic supply Gnd	
3		Hall Sensor – Phase W	
4		Hall Sensor – Phase V	
5		Hall Sensor – Phase U	
6		5V logic supply positive.	
12-24V Motor – Header Terminal			
Pin	Label	Brushless DC	Brushed DC
1	U	Phase U	Motor +
2	V	Phase V	N/C
3	W	Phase W	Motor -
4	Gnd	Motor Cable Shield Earthing point	
PS/2 Serial Terminal			
Pin	Label	Description	
1/5		N/C	
2		RX (5V Serial protocol connection)	
3		Gnd	
4		5VDC	
6		TX (5V Serial protocol connection)	

Appendix 3: Accessories for TEK6

Encoder Adaptors

Single Ended Encoder

Cable	Definition	AMT103-V
1-Brown	CH B	B
2-Red	+5V	5V
3-Orange	CH A	A
4-Yellow	INDEX	X
5-Green	GROUND	G



Sample single ended Encoder



PIN-OUT	
PIN	DESCRIPTION
B	B CHANNEL
5V	+5VDC POWER
A	A CHANNEL
X	INDEX OUTPUT
G	GROUND

Differential Encoder

IDE-10 Cable	Definition	CAT-5 cable
1	GND	1
2	GND	1
3	-INDEX	3
4	+INDEX	4
5	-CH A	5
6	+CH A	6
7	+5V	2
8	+5V	2
9	-CH B	7
10	+CH B	8



O3. Support

If you have any problems or questions please contact your distributor using the details below. You will also find a significant amount of useful material on the Internet. Please visit the CNCTeknix web site where you will find the latest support information, down loads and links to other valuable web resources. The Web resources and forums will be invaluable in putting your CNC machine to maximum use and gaining further ideas and insights into how to derive maximum usefulness and enjoyment from your equipment.

For Contact, Sales and Technical Information:

China

Talent Information Technology (Beijing) Co. Ltd
No.121 Xinhua Street, Tongzhou,
Beijing, China.
101149
Tel : 010-6952 1211 / 1611
Fax : 010-6354 7280
Email

Australia

CNC Teknix Pty. Ltd.
113 Industrial Rd.
Oak Flats, N.S.W., 2529
Australia.

In Australia Please Telephone: 02 4257 4111
Send Faxes to: 02 4257 4811

Callers from outside Australia Please Telephone: +61 2 4257 4111
Send Faxes to: +61 2 4257 4811

E-MAIL:

technical@cncteknix.com (For all technical questions and information)

sales@cncteknix.com (For all purchase information)

NOTES



113 Industrial Rd, Oak Flats,
NSW 2529 AUSTRALIA
Tel 02 4257 4111 Fax 02 4257 4811
International +61-2-42574111
Email sales @cncteknix.com
Website www.cncteknix.com